



# INSTRUCTION MANUAL

ENGLISH



## **CT-T1**

Current Transformer Tester

Raytech USA, 118 S. 2nd Street, Perkasio, PA 18944  
[www.RaytechUSA.com](http://www.RaytechUSA.com)



## **Contacts**

### **Raytech**

Raytech USA  
118 S. 2<sup>nd</sup> Street  
Perkasie, PA 18944

Phone: 267 404 2676  
Toll Free: 888 484 3779  
Fax: 267 404 2685  
Mail: [Info@RaytechUSA.com](mailto:Info@RaytechUSA.com)  
Web: [www.RaytechUSA.com](http://www.RaytechUSA.com)

### **Your local representative**



Document number: 160812.002-us  
Document revision: 0.18  
Last changed: 15 Jan 2020



## **Safety Precautions**

The following safety precautions must be observed during all phases of operation, service and repair of this instrument. By purchasing this equipment the purchaser assumes all liability for the operation and use of this equipment. The intended use of the instrument, its design and manufacture, is to be conducted within the precautions or other specific warnings located within this manual. Failure to comply with these precautions and other specific warnings violates the safety standards of design, manufacture, and intended use. Raytech assumes no liability for the operation and use of this equipment.

### **Safe Operation**

Only qualified, knowledgeable persons should be permitted to or attempt to operate this test equipment. All test personnel should fully familiarize themselves with the correct application and operation of this and all test equipment prior to operation. Persons directly and indirectly engaged in the operation of this test equipment should keep clear of all high voltage apparatus while conducting tests and measurements.



**WARNING!**

Never connect the instrument to an energized transformer!

### **Ground the Instrument**

The power cord supplied with the equipment must be connected to an electrical receptacle with an electrically grounded terminal (Earthed Ground). To minimize shock hazard, the Ground Terminal on the instrument must be properly connected to an Earth grounded point. In many cases, the quality of the safety ground terminal provided by the power cord does not fulfill the safety requirements.



**WARNING!**

Non-grounded instruments are dangerous and may cause damage to personnel and to the instrument.



## SAFETY PRECAUTIONS (cont'd)

### **Before Applying Power**

Read this manual carefully before operating the system. The instruments are line operated. They operate from a wide range of power input from 90 Vac to 264 Vac and 47 Hz to 63 Hz with automatic ranging.

### **Keep Away from Live Circuits**

Operating personnel must not remove instrument covers. Component replacement and internal repairs must be made by qualified service personnel. Do not replace components or service this instrument with the power cable connected. To avoid injuries, always discharge circuits, disconnect power and remove external voltage sources before touching components.

### **Do Not Operate in an Explosive Atmosphere**

Do not operate the instrument in the presence of flammable gases or fumes.

### **Do Not Substitute Parts or Modify Instrument**

Because of the danger of introducing additional hazards, do not install substitute parts or perform any unauthorized modification to the instrument. Return the instrument to a Raytech service department for service to ensure proper operation and that safety features are maintained.

Instruments, which appear damaged or defective, should be made inoperative and secured against unintended operation until they can be repaired by qualified service personnel.



# Unpacking

Table 1: The instrument consists of these items



The Instrument



Cable bag



Instruction manual



X-cable set



Surveillance



Safety Ground Cable



H-cable extension



H-cable clamp adapter



H-cable lug adapter



Power cord  
(dependent upon country of distribution)



2 Paper Rolls and 2 Fuses



USB Memory Stick



## **Technical Specifications**

Table 2: CT-T1 Technical Specifications

---

Type	CT-T1
Size	L: 521 mm (20.5") W: 432 mm (17") H: 216 mm (8.5")
Weight	20 kg (44lbs)
Input Power	115/230 V, 50/60 Hz, auto ranging
Output Voltage	0 V to 2000 V
Output Current	0 A to 10 A
Output Power	0 kW to 2 kW
Ratio Range	0.9 to 15 000
Panel Display	5.7" Color LCD with back light and touch screen, additional digipot
Front Panel	Sealed anodized
Interface	2 x USB 2.0 (1 host / 1 device) and 9 Pin RS232 serial
Memory Storage	Data storage of more than 10,000 measurements

---

Table 3: CT-T1 Accuracy

	<b>Range</b>	<b>Accuracy</b>	<b>Resolution</b>
<b>Ratio</b>	0.9 to 5000	$\pm 0.05\%$	5 Digits
	5001 to 10,000	$\pm 0.5\%$	5 Digits
	10,001 to 15,000	$\pm 1\%$	5 Digits
<b>Voltage</b>	0 V to 2000 V	1 %Rdg $\pm 0.1$ V	0.01 V
<b>Current</b>	0 A to 10 A	1 %Rdg $\pm 1$ mA	0.01 mA



# Contents

<b>Contacts</b>	<b>i</b>
<b>Safety Precautions</b>	<b>ii</b>
<b>Unpacking</b>	<b>iv</b>
<b>Technical Specifications</b>	<b>v</b>
<b>Contents</b>	<b>1</b>
<b>List of Figures</b>	<b>3</b>
<b>List of Tables</b>	<b>4</b>
<b>1 Quick Start Guide</b>	<b>5</b>
1.1 Measuring Setup .....	5
1.2 Measuring Process .....	6
1.3 Data Storing, Printing & Loading .....	9
<b>2 Introduction</b>	<b>11</b>
2.1 General .....	11
2.2 Advantages & Features .....	12
2.3 System Details .....	12
2.4 Square log-log Graph .....	13
2.5 Slope & Angle Calculations .....	13
2.6 Measurement Method .....	15
2.7 Standard Knee Points.....	17
<b>3 Ratio Measuring Setup</b>	<b>19</b>
<b>4 Operation Elements</b>	<b>21</b>
4.1 Main Input, Main Switch & Fuse .....	22
4.2 USB Interface .....	22
4.3 RS Interface .....	22
4.4 Surveillance Switch .....	22
4.5 Thermal Printer .....	22
4.6 Rotary Encoder with Push-Button .....	22
4.7 Safe Indicator .....	23
4.8 Display with Touch Panel .....	23



CONTENTS (cont'd)

4.9 Safety Ground .....	23
4.10 X-Current and Sense Receptacles.....	23
4.11 H-Sense Receptacle .....	23
4.12 Emergency Stop.....	24
<b>5 Operation Menu</b>	<b>25</b>
5.1 Main Screen .....	25
5.2 Measuring.....	26
5.3 Profile.....	27
5.4 Data Observation & Archive .....	27
5.5 Setup.....	29
<b>6 Interfaces</b>	<b>32</b>
6.1 Hardware .....	32
<b>7 Firmware Update</b>	<b>34</b>
<b>Appendices</b>	<b>36</b>
<b>Warranty Conditions</b>	<b>55</b>





## List of Figures

1.1	Discrete measurement setup.....	5
2.1	Square log-log graph.....	13
2.2	Excitation diagram.....	14
2.3	Excitation measurement setup.....	16
2.4	Turns ratio measurement setup.....	16
3.1	Built-in measurement setup.....	19
3.2	CT under test built into power transformer (TR factor 2/3) . .	20
3.3	CT under test built into power transformer (TR factor 1/3) . .	20
4.1	Overview of the CT-T1's operation elements.....	21
5.1	CT-T1 operation menu structure.....	25
5.2	Tap configuration.....	26
5.3	Measuring live view.....	27
5.4	Profile <i>Info</i> .....	28
5.5	Data observation.....	28
5.6	Archive.....	29
5.7	Setup screens.....	30
6.1	CT-T1 hardware interfaces.....	32
6.2	CT-T1 surveillance switch.....	33
7.1	Firmware update process.....	35
A.1	T-Base Pro example setup.....	39
A.2	T-Base Pro application example.....	41
A.3	T-Base Pro—totally free.....	42
A.4	Create your Add-On with T-Base SDK.....	43
A.5	T-Base Pro Remote Option for Raytech Devices.....	43
A.6	Proprietary Add-On—Sequence.....	44
A.7	Proprietary Add-On—Remote I/O to External Software.....	44
A.8	T-Base Pro—Data management.....	45
A.9	T-Base Pro—Sequence.....	45



## **List of Tables**

1	The instrument consists of these items.....	iv
2	CT-T1 Technical Specifications.....	v
3	CT-T1 Accuracy.....	v
1.1	Instrument operation—Measuring.....	6
1.2	Instrument operation—Storing, printing & loading.....	9
6.1	CT-T1 RS-232 parameters .....	32
6.2	CT-T1 surveillance switch.....	33
C.1	CT-T1 RS-232 parameters.....	48
D.1	Suggested Printers.....	50



## Quick Start Guide

### 1.1 Measuring Setup

Before starting a measurement, connect the CT under test to the CT-T1. An example setup is depicted in Figure 1.1 and the steps to perform the measurement are given in Table 1.1.

The measurement results can be stored and printed on the internal 3" printer. If the *Auto Print Results* option is selected, the results will be printed automatically with the date and time fields set already. Table 1.1 describes the procedure to store the results on the internal memory and—if the *Auto Print Results* option is not selected—to print the results.

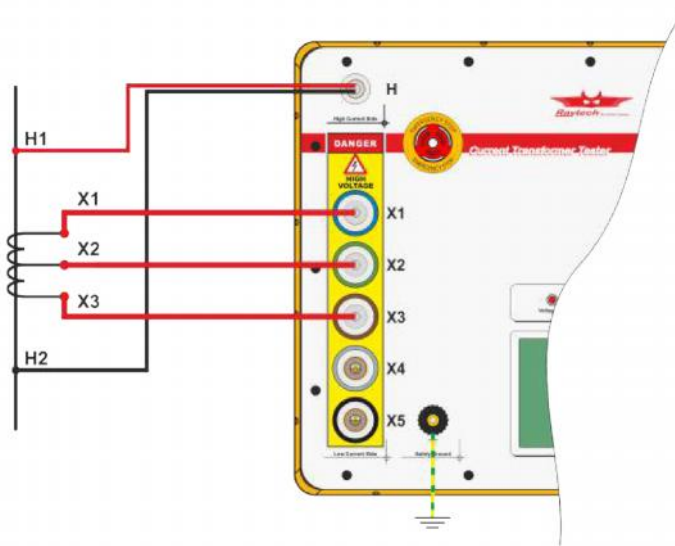

Figure 1.1: Example measurement with a three taps CT under test connected to the power transformer on the secondary winding. The primary winding of the power transformer is short circuited to prevent excess voltage.



**NOTE:**

Please always connect the safety ground before starting any measurements.



## 1.2 Measuring Process

Table 1.1: Instrument operation—Measuring

1. Configure the CT-T1 to measure the example setup depicted in Figure 1.1 above. Power the CT-T1 and you will be presented with the tap configuration.

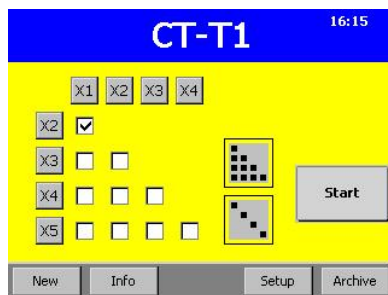

2. After pressing *Info* you see the *Rated Current* screen. Enter the appropriate values and press *OK*.

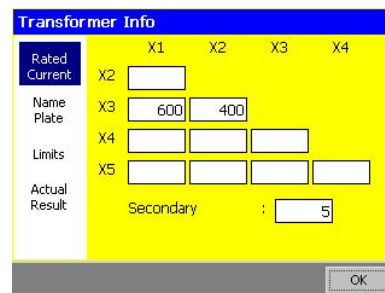

3. The tap selection is updated according to the values in the *Rated Current* screen. If you do not know the rated currents you can double tap the *Select All* button on the top right to clear the selection and press to *X3* on the left. Finally press and hold the *Start* button.

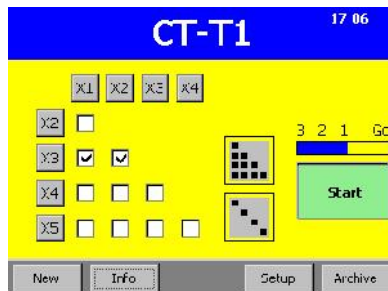

4. The *Degauss* process starts. In this phase the voltage is increased until the slope is flat enough. Please note the red area on the top of the graph that disappears when the *Surveillance Switch* is pressed.

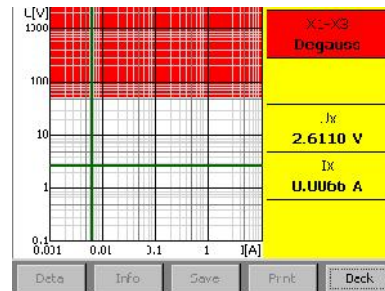

Continued on next page

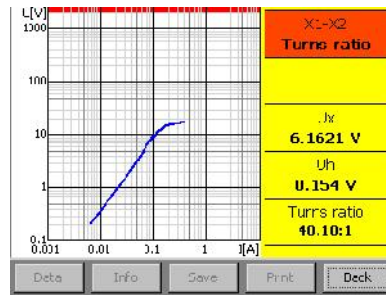

Table 1.1 – continued from previous page

5. During the *Excitation* process, the voltage is slowly decreased until the slope is steep enough and the graph is extended. Please keep holding down the *Surveillance Switch* as long as the voltage is above 50 V.



6. The *Turns ratio* is measured at different voltages below the detected *Knee point*. Please keep holding down the *Surveillance Switch* during this phase as the voltage might be increased above 50 V depending on the detected *Knee point*.



7. The second winding is measured in the same way. Starting with another *Degauss* process.



8. The *Excitation curve* for the second winding is drawn on the same diagram.



Continued on next page

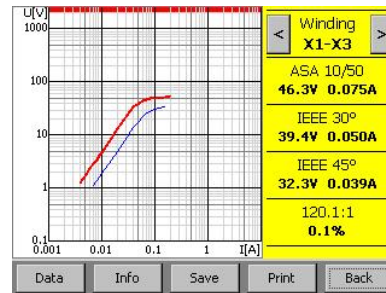

Table 1.1 – continued from previous page

9. The measurement process is completed with the *Turns ratio* determination for the winding X2-X3.



10. The results are shown after all measurements have been concluded. The first winding is high-lighted in red and the values are listed on the right.



11. The second winding can be highlighted using the *left* and *right* buttons on the top.

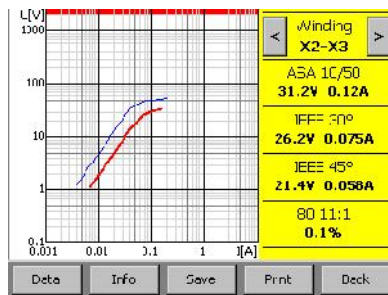

12. After pressing *Back* the available results are marked in the *Main* screen.

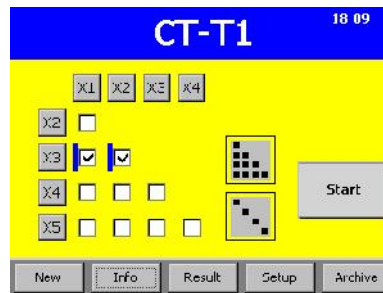



### 1.3 Data Storing, Printing & Loading

The profile data of the CT under test is accessed by pressing *Info*. The measurement results of the currently active profile are displayed by pressing *Result*. The *Data* button displays the raw data points.

Table 1.2: Instrument operation—Storing, printing & loading

1. Available results are marked on the *Main* screen.

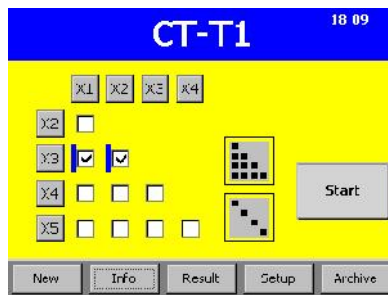

2. By pressing *Info* and *Name Plate* the characteristics of the CT under test can be entered.

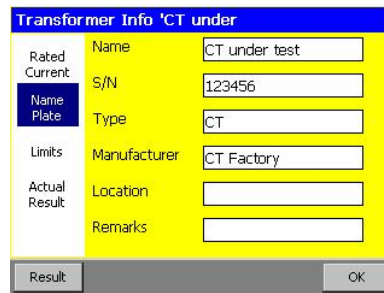

3. If the CT under test is sensitive and certain voltage or current values must not be exceeded these limits can be set in the *Limits* tab.

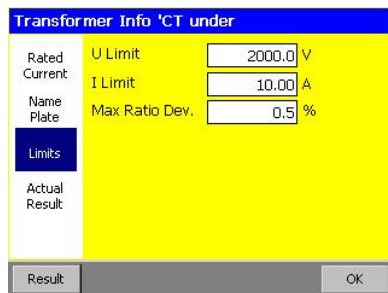

4. The date, time, device name, and the serial number of the CT-T1 are listed in the *Actual Result* screen.



Continued on next page



Table 1.2 – continued from previous page

5. From the *Result* screen measurements can be *Saved* into the *Archive* and *Printed* as well as the raw *Data* being displayed.

6. To display the raw data points press *Data* from the *Result* screen.

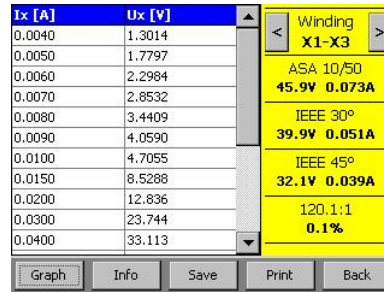
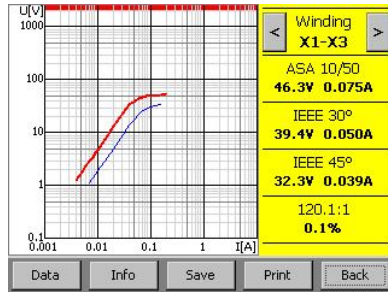





## **Introduction**

### **2.1 General**

The Raytech Current Transformer Tester is a fully automatic knee point and turns ratio measuring device with a built-in polarity detection system. It is designed for a high degree of accuracy and ease of use.

**Ease Of Use:** This intelligent system has an easy-to-use operation screen which allows quick measurement setup. It incorporates a touch screen which allows the user easy access to change or activate a feature.

**Impressive Accuracy:** The CT-T1 has a high precision, fully automatic, multi-microprocessor based architecture. This system is designed for highly accurate readings on-site with laboratory precision.

**Fully Automatic Measuring Technique:** The standard excitation and turns ratio measurement methods described in [6] are implemented in a fully automatic fashion.

**Operation:** Up to ten winding combinations can be selected in advance and these combinations are measured sequentially without any further interaction. The process is displayed live on the screen.

**Compact Design:** The CT-T1 instrument is available in its own rugged waterproof field case.

**Simple Maintenance:** There is no maintenance required. There is no calibration procedure (no potentiometers to turn). This is due to the utilization of high precision components in the design.



**NOTE:**

The CT-T1 field case is a waterproof design. A pressure regulator activates when the case is opened to compensate for atmospheric pressure changes. The field case is not a shipping container.



## 2.2 Advantages & Features

- Fully automatic knee point detection (ASA 10/50, IEEE 30°, IEEE 45°)
- Ratio range of 0.9 to 15,000
- 5 low side taps, 1 high side tap
- Performs CT excitation, turns ratio, and polarity tests on current transformers
- Manual or automatic degauss and measurements
- Easy, one-time hook up for up to 5 CT taps
- Automatic test voltage range with changeable limits
- Easy to use tap selector interface
- Data storage of more than 10,000 measurements
- Color 5.7" LCD touch screen display for easy operation
- 3" graphic-capable printer
- Two USB interfaces and one RS-232 serial port
- Mounted in rugged case for field testing
- 5-Year standard warranty

## 2.3 System Details

### 2.3.1 System Check

The instrument is line operated. The system is designed to be used with either 115V 60 Hz or 230 V 50 Hz. The system performs a self-check each time that it is powered on. The User should always visually inspect all connectors, cables and devices to be measured to avoid any safety issues.

### 2.3.2 Limitations of Testing

In general, there are no limitations on testing low or high turns ratios or knee points. The test system is specially designed to test all current transformers in the output voltage and current ranges specified in Table 2.

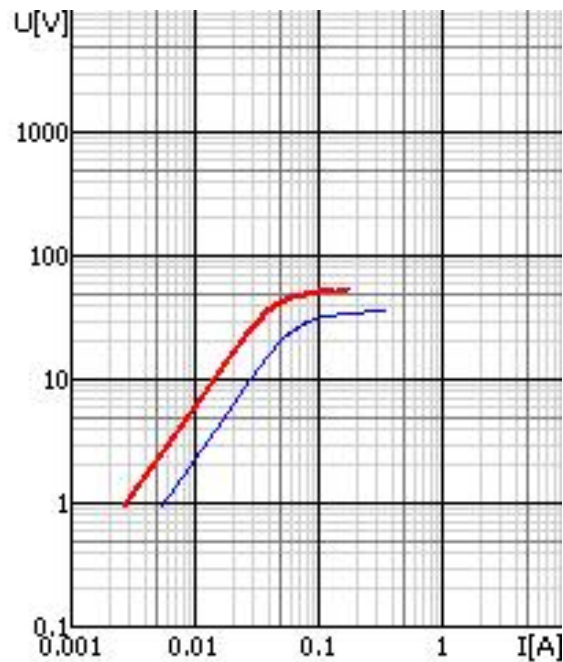

Figure 2.1: Square log-log graph

## 2.4 Square log-log Graph

The graph used to display the results and determine the IEEE 30° and IEEE 45° (see Sections 2.7.2 and 2.7.3) show two log-axis with each decade forming a square. It is depicted in Figure 2.1. Both axes are scaled logarithmically with the decade divisions forming squares.

## 2.5 Slope & Angle Calculations

The excitation diagram shown in Figure 2.2 depicts the terms used in the following Section. The graph plots the logarithm of the current on the horizontal axis and the logarithm voltage on the vertical axis. The blue region is the knee point with a slope  $S_{KP}$ . It is calculated with Equation 2.1 and transferred to the angle  $\theta_{KP}$  using Equation 2.3. The CT under test is saturated in the red region above the knee point where  $S_{SAT} < S_{KP}$ . In the green region — below the knee point — the CT under test is in the linear operating state with  $S_{LIN} > S_{KP}$ .

Chapters 2.6.1 and 2.6.2 describe the determination of the saturation condition and the knee points of the CT under test. The secondary voltage and current values of two subsequent measurements are used in order to calculate the slope and the angle of the point on the excitation curve.

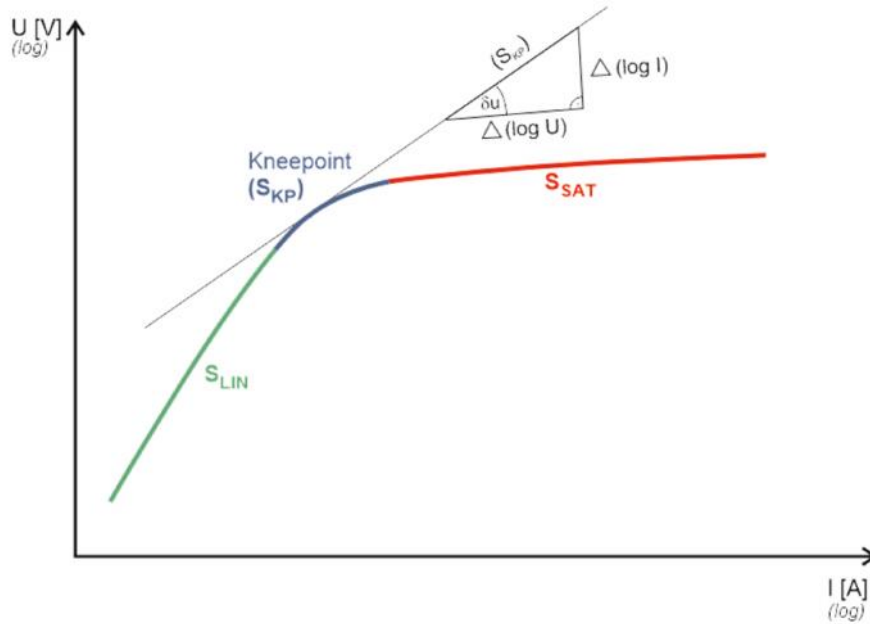

Figure 2.2: Excitation diagram

Each measurement  $k$  leads to a pair of values  $(I_k, U_k)$ . The horizontal  $x$ -value is  $\log I$  and the vertical  $y$ -value is  $\log U$ . The slope  $s$  between two subsequent measurements  $n$  and  $n + 1$  is calculated using the slope properties of the log-log graph:

$$s = \frac{\Delta y}{\Delta x} = \frac{\Delta \log I}{\Delta \log U} = \frac{\log I_{n+1} - \log I_n}{\log U_{n+1} - \log U_n} = \frac{\log \frac{I_{n+1}}{I_n}}{\log \frac{U_{n+1}}{U_n}} \quad (2.1)$$

The angle  $\sigma$  can be calculated by using Equation 2.2:

$$\tan \sigma = \frac{\Delta y}{\Delta x} \quad (2.2)$$

The combination of Equations 2.1 and 2.2 leads to the conversion of the slope and the angle.

$$\begin{aligned} s &= \tan \sigma \\ \Leftrightarrow \sigma &= \arctan s \end{aligned} \quad (2.3)$$



## 2.6 Measurement Method

The measurement method as described in ANSI/IEEE C57.13.1, IEC 60044-1 standards is implemented in the CT-T1. The CT-T1 applies an AC variable test voltage (up to 2000 Vac) to the CT's secondary windings. The test voltage and excitation current are applied to the CT under test during the excitation measurement process. Once tests are completed, the results can be saved internally or printed on the built-in printer. IEEE-30, IEEE-45, ANSI/IEC 60044-1 (10/50) knee point voltages are also calculated and printed on the test report.

The CT-T1 determines the CT current-ratio using the ANSI/IEEE C57.12.90 measurement method. A test voltage is applied on the CT's X terminals and the induced voltage is measured across the CT's H1 and H2 terminals. The current-ratio is displayed on the screen and stored in memory. The current-ratio measuring range is from 0.9 to 15,000. Winding polarity is displayed as a plus sign (in-phase) or minus sign (out-of-phase).

### 2.6.1 Degauss

To get rid of previously induced magnetization—also called remanence—of the CT under test it is demagnetized by saturating the core for a certain amount of time.

The slope of the curve in the square log-log graph (see Section 2.4) is used to determine the state of the CT under test's core. Figure 2.2 shows a simplified square log-log graph containing a generic knee point with an associated slope  $s_{Sat}$ . The core is assumed to be sufficiently saturated above of the knee point.

The slope is used to identify the saturation state since it is more flat compared to the core's linear region and at the generic knee point. The highest and therefore flattest knee point as defined in Section 2.7 is ASA 10/50:  $S_{ASA\ 10/50} = 0.235$ . The saturation region is higher and the threshold for the saturation region is defined as:

$$s_{Sat} := 0.2 < S_{ASA\ 10/50} \quad (2.4)$$

For the degauss process the output voltage  $U$  is set to a value below the saturation voltage  $U_{Start}$  and is increased until the slope  $s$  is flatter than  $s_{Sat}$ . Subsequently the voltage is stationary while the CT under test is demagnetized.



#### WARNING!

If the voltage is applied to a section of the secondary winding, the voltage on the full winding is proportionally higher due to the autotransformer characteristics!

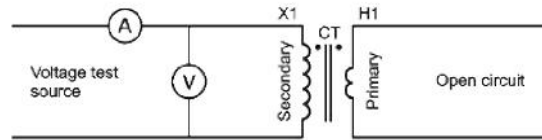

Figure 2.3: Excitation measurement setup

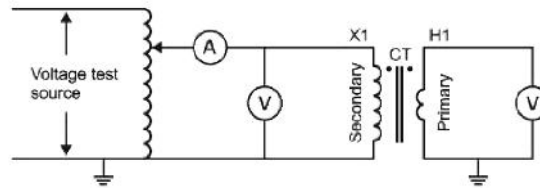

Figure 2.4: Turns ratio measurement setup

### 2.6.2 Knee Point/Excitation

After the process of eliminating the remanence, the knee points detecting phase is started. For a thorough discussion about the three standard knee points see Chapter 2.7.

Figure 2.3 shows the measurement setup for the excitation measurement process.

At the beginning of the knee point detection phase, the voltage  $U_X$  and the current  $I_X$  are high for the CT under test to be demagnetized.  $U_X$  — and thus  $I_X$  — are slowly decreased until the slope is steep enough to allow the detection of the lowest (IEEE-45) knee point. The voltage  $U_X$  is decreased faster in the linear area to complete the graph.

### 2.6.3 Turns Ratio

The turns ratio  $TR$  of a CT is usually given as the ratio of the rated primary current  $I_H$  versus the rated secondary current  $I_X$  (see Equation 2.5).

In the measurement setup shown in Figure 2.4 the secondary winding is negligibly loaded only by the voltage measurement of the CT-T1. If, in addition, the measuring voltage  $U_X$  is below the knee point voltage of the CT under test, the energy in the primary winding is the same as the energy in the secondary winding and Equation 2.6 is true.



$$TR = \frac{I_H}{I_X} \quad (2.5)$$

$$U_X \cdot I_X = U_H \cdot I_H \quad (2.6)$$

Combining Equations 2.5 and 2.6 leads to the method (see Equation 2.7) used to measure the turns ratio by the CT-T1.

$$TR = \frac{U_X}{U_H} \quad (2.7)$$

The polarity is determined simultaneously by measuring the phase shift of the two time variant voltages ( $u_X(t)$  and  $u_H(t)$ ). It is considered positive if the phase is around  $0^\circ$  and the turns ratio displayed on the device is positive; otherwise — if the phase is around  $180^\circ$  — the polarity is considered negative and the turns ratio is negative as well.

As previously mentioned Equation 2.6 is only valid if the exciting voltage  $U_X$  is lower than the knee point voltage. The method of determining this voltage is described in Chapter 2.6.2.

## 2.7 Standard Knee Points

The CT-T1 is able to fully automatically determine three different knee points which are listed below and described in Sections 2.7.1 to 2.7.3.

**ASA 10/50** The point in the square log-log graph where increasing the voltage by 10 % leads to an increase of the current by 50 %.

**IEEE 30°** The knee point of a CT with a gapped core as defined by the Institute of Electrical and Electronics Engineers (IEEE). The tangents slope is  $30^\circ$  in the log-log-graph with square decades.

**IEEE 45°** The knee point of a CT with a non-gapped core as defined by the Institute of Electrical and Electronics Engineers (IEEE). The tangents slope is  $45^\circ$  in the log-log-graph with square decades (see Definition 3.11(A) of [5]).

The listed knee-points above are defined in [5]. They both appear in [4] as well:

1. Definition 3.11(A) for Class C transformers (described in [6]). They are described in Section 2.7.2 (IEEE  $30^\circ$ ) and Section 2.7.3 (IEEE  $45^\circ$ ).
2. Definition 3.11(B) derived from [3] (described in [4]). The ASA 10/50 knee-point is described in 2.7.1.



### 2.7.1 ASA 10/50

The ASA 10/50 was first described in [3] in 1973. ASA stands for the *American Standards Association* which is now the *American National Standards Institute* (ANSI). The ASA 10/50 voltage is easily determined by applying the measurement method from Section 2.6.2 and finding the voltage at which its increase leads to a current increase of 50%.

If the first voltage  $U_0$  is normalized to 1 a 10% increase leads to  $U_1 = 1.1$  and respectively for the current  $I_1 = 1.5$ . Using Equations 2.1 and 2.3 leads to the slope  $m_{ASA\ 10/50}$  and angle  $\sigma_{ASA\ 10/50}$ .

$$S_{ASA\ 10/50} = \frac{\log \frac{I_1}{I_0}}{\log \frac{U_1}{U_0}} = \frac{\log 1.1}{\log 1.5} \quad (2.8)$$

$$S_{ASA\ 10/50} \approx 0.235$$

$$\sigma_{ASA\ 10/50} = \arctan \frac{\log \frac{I_1}{I_0}}{\log \frac{U_1}{U_0}} = \arctan \frac{\log 1.1}{\log 1.5} \quad (2.9)$$

$$\sigma_{ASA\ 10/50} \approx 13.2^\circ$$

### 2.7.2 IEEE 30°

The Institute of Electrical and Electronics Engineers (IEEE) defines the knee point for Class C transformers with gapped cores as the point in the square log-log graph whose tangent makes an angle  $\sigma_{IEEE\ 30^\circ}$  of  $30^\circ$  to the abscissa (horizontal  $I$ -axis). Using Equation 2.3 leads to the slope  $m_{IEEE\ 30^\circ}$ .

$$S_{IEEE\ 30^\circ} = \tan \sigma_{IEEE\ 30^\circ} = \tan 30^\circ \quad (2.10)$$

$$\begin{aligned} S_{IEEE\ 30^\circ} &= 0.577 \\ \sigma_{IEEE\ 30^\circ} &= 30^\circ \end{aligned} \quad (2.11)$$

### 2.7.3 IEEE 45°

The IEEE knee point of a Class C transformers with non-gapped cores makes an angle  $\sigma_{IEEE\ 45^\circ}$  of  $45^\circ$  to the abscissa (horizontal  $I$ -axis). Using Equation 2.3 leads to the slope  $m_{IEEE\ 45^\circ}$ .

$$S_{IEEE\ 45^\circ} = \tan \sigma_{IEEE\ 45^\circ} = \tan 45^\circ$$

$$S_{IEEE\ 45^\circ} = 1 \quad (2.12)$$

$$\sigma_{IEEE\ 45^\circ} = 45^\circ \quad (2.13)$$





## Ratio Measuring Setup

The most accurate turns ratio results are achieved if the CT under test can be connected as depicted in Figure 1.1 *Discrete measurement setup* on page 5 and measured discretely. In case this is not possible—because the CT under test is built into a power transformer and the high current taps are not accessible—it can be measured as a part of the power transformer. Special attention has to be devoted to not measuring any additional voltage.

Figure 3.1 shows a built-in CT under test and the power transformer's associated primary and secondary windings. A jumper is used to short circuit the primary winding of the power transformer and thus eliminating the additional voltage  $U$  induced (due to the turns ratio measurement) into the secondary winding.

If the CT under test is built into a winding power transformer and the according winding cannot be short circuited, a compensation factor needs to be applied. Figures 3.2 and 3.3 show the measurement setup and the equivalent circuit of the high current side.

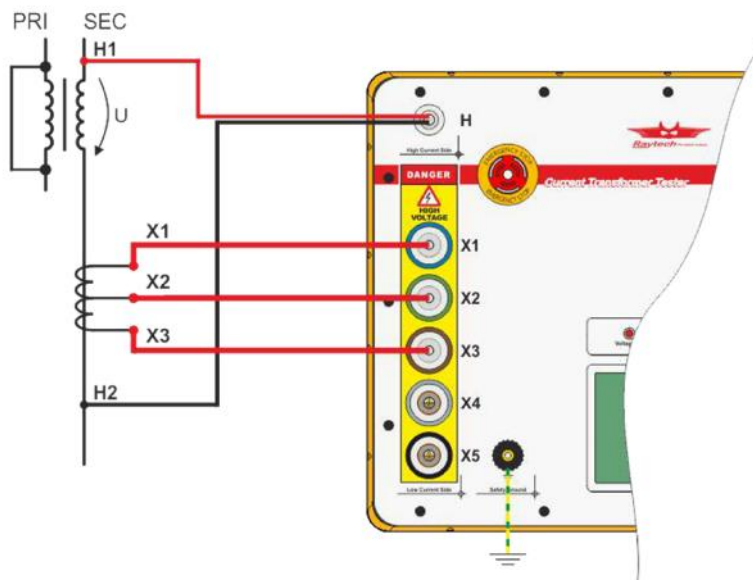

Figure 3.1: Example measurement with a built-in three taps CT under test connected to the power transformer on the secondary winding. The primary winding of the power transformer is short circuited to prevent any voltage  $U$  on the secondary winding of the power transformer.

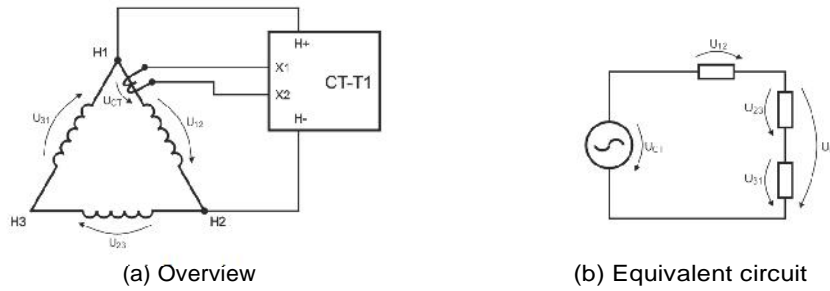

Figure 3.2: CT under test built into power transformer (TR factor 2/3)

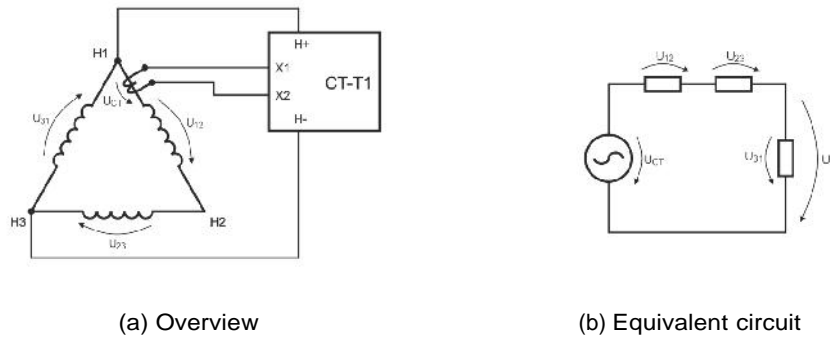

Figure 3.3: CT under test built into power transformer (TR factor 1/3)

The turns ratio factor is determined depending on the connection of the *H1-H2* cables of the CT-T1:

- A turns ratio correction factor of  $2/3$  needs to be applied if the *H1- H2* cables of the CT-T1 are connected to the CT under test and the associated coil (Figure 3.2).
- A turns ratio correction factor of  $1/3$  needs to be applied if the *H1-H2* cables of the CT-T1 are connected to an independent coil (Figure 3.3).



## Operation Elements

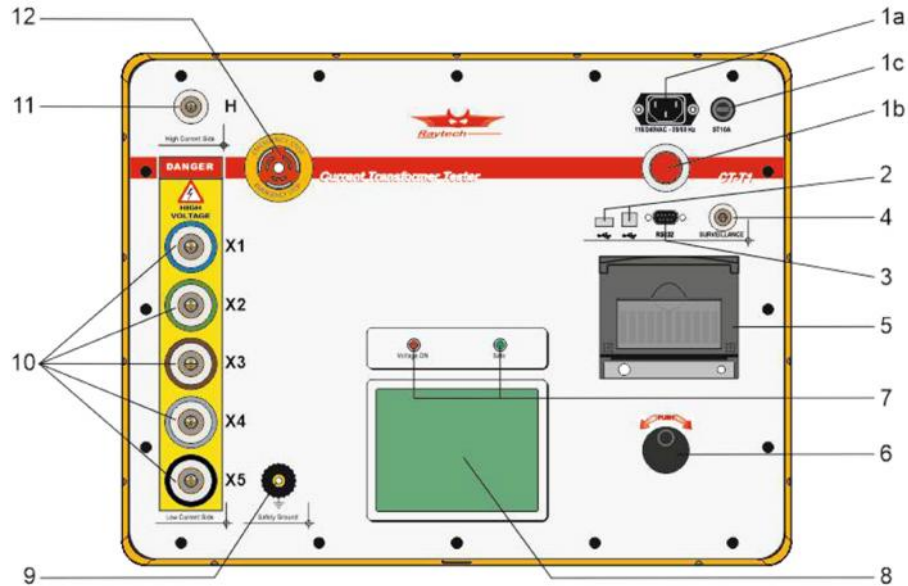

Figure 4.1: Overview of the CT-T1's operation elements

Figure 4.1 depicts the operation elements of the CT-T1.

- |                                       |                                     |
|---------------------------------------|-------------------------------------|
| 1. Mains                              | 6. Rotary Encoder with Push Button  |
| a) Main Input                         |                                     |
| b) Main Switch                        | 7. Safe Indicator                   |
| c) Fuse (16 A ST)                     | 8. Display with Touch Panel         |
| 2. USB Interface (1x Host, 1x Device) | 9. Safety Ground                    |
| 3. RS Interface (1xRS-232)            | 10. X-Current and Sense receptacles |
| 4. Surveillance Switch                | 11. H-Sense receptacle              |
| 5. Thermal Printer                    | 12. Emergency Stop                  |



## 4.1 Main Input, Main Switch & Fuse

Connect the power cable to the Main Input (Figure 4.1-1a). Press the Main Switch (Figure 4.1-1b) to switch the CT-T1 on / off.

A 16 A ST (super slow blow) fuse (Figure 4.1-1c) protects the device. Use only the correct fuse type to replace it.

## 4.2 USB Interface

- 1x USB Host
- 1x USB Device

Element 2 of Figure 4.1 shows the USB Interfaces of the CT-T1. See Section 6.1.2 for details.

## 4.3 RS Interface

- 1x RS-232

Element 3 of Figure 4.1 shows the RS-232 Interface of the CT-T1. See Section 6.1.1 for details.

## 4.4 Surveillance Switch

- 1x 4-pin Surveillance Switch connector

The Surveillance Switch receptacle is depicted as Element 4 in Figure 4.1. See Section 6.1.3 for details.

## 4.5 Thermal Printer

Allows you to quickly get your results on paper by using the built-in thermal printer (Figure 4.1-5).

## 4.6 Rotary Encoder with Push-Button

Figure 4.1-6



## 4.7 Safe Indicator

**Green Light on** System is in safe mode. Ready for handling test leads and connections.

**Red Light on** Unsafe mode! Do not remove any cables, there is current flowing and voltage on the test leads!



**WARNING!**

Potentially deadly voltage is present on the test leads! Do not touch them or the CT under test in any case. Use the Emergency Switch (Figure 4.1-12) to immediately deactivate the output voltage.

## 4.8 Display with Touch Panel

The instrument can be easily manipulated and fully controlled by the touch screen panel. If preferred, an external mouse or keyboard can be connected to the USB Port (Figure 4.1-2) to control the system.

## 4.9 Safety Ground

Use this terminal (Figure 4.1-9) to ground the CT under test.



**WARNING!**

Always ground the CT under test with the included Safety Ground cable to prevent dangerous voltage on the case of the CT under test.

## 4.10 X-Current and Sense Receptacles

Use the appropriate X-cable to connect the secondary terminals of the CT under test with the X-Current and Sense receptacles (Figure 4.1-10).

## 4.11 H-Sense Receptacle

Use the appropriate H-cable to connect the primary terminals of the CT under test with the H-Sense receptacles (Figure 4.1-11).



## 4.12 Emergency Stop

Press the Emergency Stop (Figure 4.1-12) to immediately interrupt the measurement and disconnect the output voltage from the X-Current receptacle.

Turn clockwise to release. The device will remain in a safe mode state.



# Operation Menu

The instrument software is straight forward and easy to set up and operate. With a few key strokes and selections on the test screen, measurements can be started (see Chapter 1 *Quick Start Guide* on page 5).

## 5.1 Main Screen

The selection of the CT under test's windings—that are to be measured—are selected in the *Main* screen (see Figure 5.2). The grid can directly be used to select the windings.

Additionally the *Xn* buttons can be used to select all windings with the given tap. For example if you want to measure the windings X3-X4 and X3-X5 you can press X3 on the top. The symbols on the right can be used to either select all windings or all adjacent windings.

The designation can be unselected if all associated windings are marked. A button press for a certain grouping with at least one untagged winding marks all and a second press clears the selection.

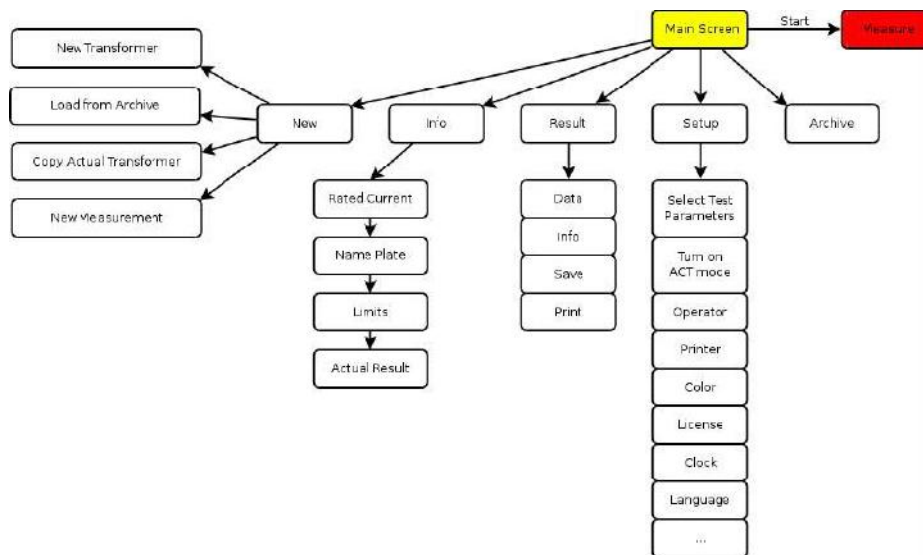

Figure 5.1: CT-T1 operation menu structure

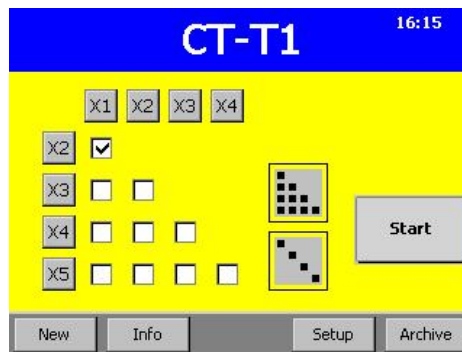

Figure 5.2: Tap configuration

## 5.2 Measuring

Press the *Start* button to perform the knee point and turns ratio measurements in a completely autonomous fashion successively for each selected winding. The measurement can be adjusted in the *Setup* screen. Please see Section 5.5 *Setup* on page 29 for more details. The name plate of the CT under test and its characteristics can be entered prior to the measurement on the *Info* screen which is described in Section 5.3 *Profile* on page 27.

The user simply has to press the *Surveillance switch* (see Section 4.4) during the automatic measurement process. The red area marks the hazardous output voltage that could harm persons. To ensure the user is aware of the situation the *Surveillance switch* needs to be pressed while the output voltage is above the limit and the red area disappears.

The progress is displayed on the screen (see Figure 5.3) while each winding is measured. The live view contains a large square log-log graph on the left. The output voltage and current are marked with the cross and are listed on the right as well. During the *Excitation* process the curve is drawn as a bold line. The previously recorded curves are displayed as thin lines.

The winding is displayed on the top right corner along with the measurement phase (*Degauss*, *Excitation* and *Turns ratio*). The background of this field changed according to the potential risk to damage the CT under test from red during the *Degauss* process to orange during the *Excitation* and *Turns ratio* processes.

To abort the measurement press *Back* or the *Emergency switch* (see Section 4.12). If the *Surveillance switch* is released while the output voltage is harmful, the measurement stops as well.





Figure 5.3: Measuring live view

### 5.3 Profile

The *Info* screen is divided into the following four tabs (see Figure 5.4):

**Rated Current** The rating for the windings can be entered in this form. These values are used to determine the turns ratio errors (Figure 5.4(a)).

**Name Plate** The name, serial number (S/N), type, manufacturer, location of the CT under test along with remarks can be stored (Figure 5.4(b)).

**Limits** To protect the CT under test limits can be set (Figure 5.4(c)).

**Results** An overview of the available results for each profile (Figure 5.4(d)).

### 5.4 Data Observation & Archive

The results of the actual CT under test can be displayed by pressing *Result*. Figure 5.5 shows the two views:

**Graph** The knee point curves for all windings in one combined graph where the windings are cycled using the < and > buttons. The curve for the selected winding is highlighted in red and the corresponding results displayed on the right (Figure 5.5(a)).

**Raw Data** The data points for the selected windings are listed on the left in a chart (Figure 5.5(b)).

In the *Archive* (Figure 5.6) results can be stored and kept for later reference. To copy a measurement into the Archive simply press *Save* in the *Result* view.

From the *Archive* results can be *Loaded*, *Deleted*, or *Exported* if a USB key is plugged into the CT-T1. A preview of the archived result is presented by pressing *Info*. An archived item is set as the active profile by pressing *Load*.



**Transformer Info**

	X1	X2	X3	X4
Rated Current	X2	<input type="text"/>		
Name Plate	X3	<input type="text" value="600"/>	<input type="text" value="400"/>	
Limits	X4	<input type="text"/>	<input type="text"/>	<input type="text"/>
Actual Result	X5	<input type="text"/>	<input type="text"/>	<input type="text"/>
	Secondary		:	<input type="text" value="5"/>

OK

(a) Rated Current

**Transformer Info 'CT under**

Rated Current	Name	<input type="text" value="CT under test"/>
Name Plate	S/N	<input type="text" value="123456"/>
Limits	Type	<input type="text" value="CT"/>
Actual Result	Manufacturer	<input type="text" value="CT Factory"/>
	Location	<input type="text"/>
	Remarks	<input type="text"/>

Result OK

(b) Name Plate

**Transformer Info 'CT under**

Rated Current	U Limit	<input type="text" value="2000.0"/>	V
Name Plate	I Limit	<input type="text" value="10.00"/>	A
Limits	Max Ratio Dev.	<input type="text" value="0.5"/>	%
Actual Result			

Result OK

(c) Limits

**Transformer Info 'CT under**

Rated Current	31.08.2016 17:03 (CTT1 362100)
Name Plate	
Limits	
Actual Result	

Result OK

(d) Results

Figure 5.4: Profile Info

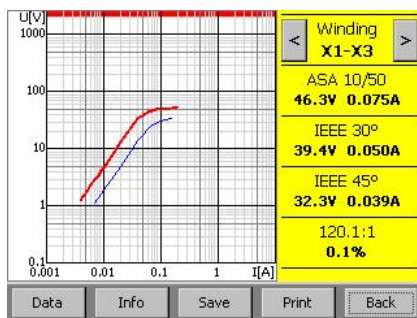

(a) Graph view

Ix [A]	Ux [V]
0.0040	1.3014
0.0050	1.7797
0.0060	2.2984
0.0070	2.8532
0.0080	3.4409
0.0090	4.0590
0.0100	4.7055
0.0150	8.5288
0.0200	12.836
0.0300	23.744
0.0400	33.113

Winding X1-X3

ASA 10/50  
45.9V 0.073A  
IEEE 30°  
39.9V 0.051A  
IEEE 45°  
32.1V 0.039A  
120.1:1  
0.1%

Graph Info Save Print Back

(b) Raw Data view

Figure 5.5: Data observation



Name	Type	SN	Location
23.08.2016			
CT under test	CT	123456	

Figure 5.6: Archive

## 5.5 Setup

The options menu is divided into four subparts which are described in the following sections.

### 5.5.1 Device settings

The device settings (Figure 5.7(a))

**License** Access the *License Manager* to see the status and extend the period.

**About** View information about the CT-T1 such as the firmware version and the serial number (SN).

**Clock** Change the date and time for the CT-T1.

**Cursor** Switch the cursor style in case you use a USB mouse.

**Update** Force a firmware update. Usually the update process is triggered automatically when you attach a USB key with a new firmware version.

**Language** Change the language of the CT-T1.

**Service** Perform system tasks using service codes.

### 5.5.2 Operator

For each measurement there is an operator assigned to it. The list of operators can be edited in this screen (Figure 5.7(b)). The active operator can be chosen or a new one can be added.

CHAPTER 5. OPERATION MENU



(a) Device settings



(b) Operator

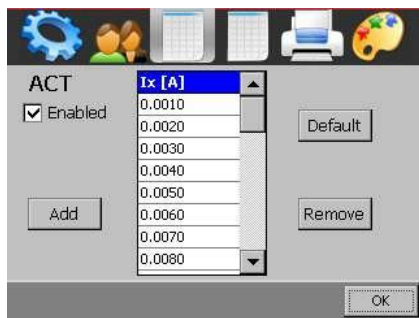

(c) ACT

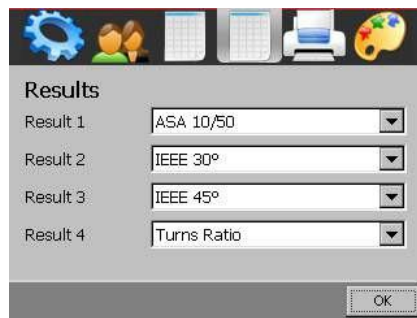

(d) Results settings

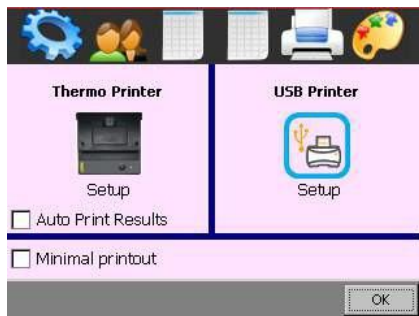

(e) Printer



(f) Colors

Figure 5.7: Setup screens



### 5.5.3 ACT

The ACT mode uses normalized current values to allow standardized measurements. These can be set and enabled in this screen (Figure 5.7(c)).

### 5.5.4 Results settings

If some results are not required, they can be disabled in the results screen (Figure 5.7(d)).

The turns ratio error is displayed along with the turns ratio if the rated current for the corresponding winding is set in the *Profile* (see Chapter 5.3 *Profile* on page 27 and Figure 5.4(a)).

### 5.5.5 Printer

Printer settings are changed on the screen as depicted in Figure 5.7(e).

The minimal printout option prevents the printing of the graph and the ACT points.

### 5.5.6 Colors

Switch between color or black and white view which is optimized for bright sunlight usage (Figure 5.7(f)).



# Interfaces

## 6.1 Hardware

The CT-T1 contains four hardware interfaces depicted in Figures 6.1 and 6.2.

### 6.1.1 RS-232

The 9-pin RS-232 interface integrated into the CT-T1 (Figure 6.1(a)) can be used with the Raytech Software Development Kit (SDK) described in Appendix B or to directly control the device using the command syntax described in Appendix C.

The interface parameters are listed in Table 6.1(a). These parameters are fixed and not changeable.

Table 6.1: CT-T1 RS-232 parameters

(a) CT-T1 RS-232 parameters		(b) USB Master standard 2.0	
Port	RS-232	<b>Pin</b>	<b>Signal</b>
Datarate	38,400 bit/s	2	T x D (CT-T1 ⇒Host)
Databit	8 bit	3	R x D (Host ⇒CT-T1)
Stopbits	1 bit	5	GND
Parity	No		

### 6.1.2 USB

The USB interface consists of a Master (Figure 6.1(b)) and a Slave (Figure 6.1(c)) connector.

The Master connector can be used to update the device as described in Chapter 7 and store/load measurement data from USB memory sticks.

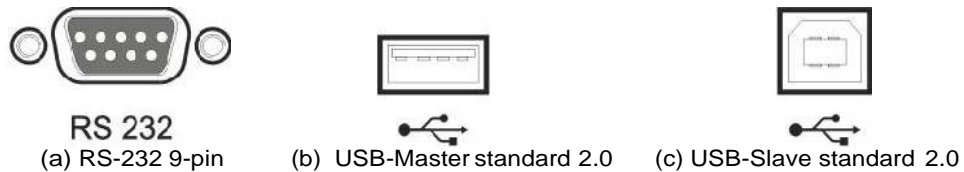

Figure 6.1: CT-T1 hardware interfaces

## CHAPTER 6. INTERFACES



(a) Pin assignment



(b) Connector in the instrument Lemo:  
ERA.1E.304.CLL  
(RAN: 40894)



(C) Extern Lemo:  
FFA.1E.304.CLAC60  
(RAN: 40895)

Figure 6.2: CT-T1 surveillance switch

### 6.1.3 Surveillance

The *Surveillance* switch (Figure 6.2) is a safety precaution to unlock dangerous output voltages. The operator has to press the switch as long as the output voltage is above 50 V.

Table 6.2: CT-T1 surveillance switch

Pin	Signal
1	Surveillance switch normally open
2	Surveillance switch normally open
3	Not connected
4	Not connected



## ***Firmware Update***

To perform a Firmware update, please copy the zip file<sup>1</sup> to a USB stick and plug it into the CT-T1. You will be asked if you want to install it (see Figure 7.1(a)). The update process will be performed after pressing *Ok*.

The new user interface firmware will be installed onto the host (Figure 7.1(b)) and the system will restart.

If a firmware update for the micro-controller on the main board is packed within the zip file, the update will be executed when the CT-T1 reboots (Figure 7.1(c)).

---

<sup>1</sup>E.g. Raytech.Firmware.CT1.Update.0.2.28.0.zip





(a) Automatic detection of new version



(b) Host update

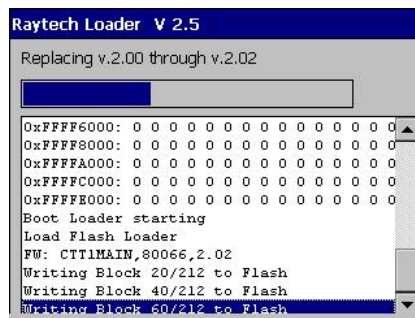

(c) Main update

Figure 7.1: Firmware update process



## Appendices



## CT-T1

### Current Transformer Tester

Raytech USA, 118 S. 2nd Street, Perkasie, PA 18944  
[www.RaytechUSA.com](http://www.RaytechUSA.com)



## **Appendices overview**

<b>A Raytech T-Base Pro</b>	<b>38</b>
A.1 Description	38
A.1.1 Advantages & Features	38
A.1.2 Specifications	39
A.1.3 Included	39
A.1.4 Options	39
A.2 Application Example	39
A.2.1 Overview	39
A.2.2 Description	40
A.3 Concept of T-Base Pro	42
A.4 Components of T-Base Pro	42
A.4.1 T-Base Pro—totally free	42
A.4.2 Create your Add-On with T-Base SDK	43
A.4.3 T-Base Pro Remote Option for Raytech Devices	43
A.4.4 Proprietary Add-On—Sequence	44
A.4.5 Proprietary Add-On—Remote I/O to External Software	44
A.5 Graphical User Interface	44
A.6 USB Driver for T-Base Pro	46
<b>B Software Development Kit (SDK)</b>	<b>47</b>
<b>C Command Syntax</b>	<b>48</b>
C.1 Serial Interface	48
C.1.1 Command Syntax	48
C.1.2 Standard Response / Error Messages	48
C.2 USB Interface	49
<b>D USB Printer Info</b>	<b>50</b>
D.1 Printer Requirements	50
D.2 Suggested Printers	50
<b>E Trouble Shooting</b>	<b>51</b>
E.1 System does not display anything:	51
E.2 Touch Panel does not work:	51
E.3 USB Memory Stick does not work:	51
E.4 Measurement cannot be turned on:	51
<b>Glossary</b>	<b>52</b>
<b>Bibliography</b>	<b>53</b>
<b>Index</b>	<b>54</b>



**Raytech** U.S.A. Inc.



## **Raytech T-Base Pro**

### **A.1 Description**

T-Base Pro [1] is a powerful tool to remotely control Raytech test instruments, exchange data and analyze measured data. It runs on Windows based PCs with a modern graphical user interface which makes it easy and intuitive to operate. Any custom request or special feature can easily be added with a custom Add-On. Figure A.1 shows an example setup.

#### **A.1.1 Advantages & Features**

- Import transformer name plate data and measuring results from devices by USB with a few clicks.
- Generate transformer name plate data sets on your PC and export them to devices.
- View measurement data in a table or diagram.
- Control devices by remote (option).
- Generate, save and print test reports.
- Store all your data in one database organized by transformers, not measuring method.

## APPENDIX A. RAYTECH T-BASE PRO

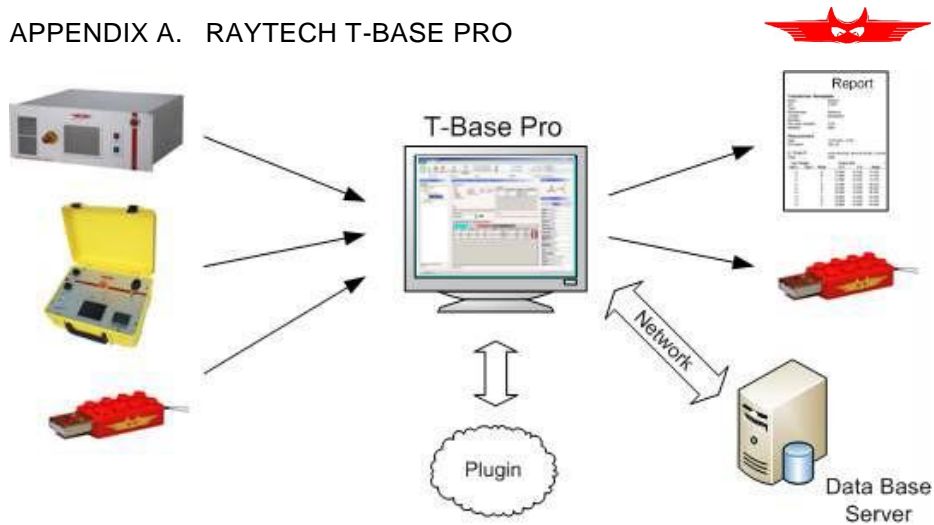

Figure A.1: T-Base Pro example setup

- Use powerful search functions to find your measurements quickly.
- Work with a clearly arranged user interface.
- Easily integrate individual software plug-ins to expand T-Base Pro to meet your needs.

### A.1.2 Specifications

**Operating System:** Min. Win XP (SP3), Win Vista or 7

**Hardware:** Pentium 4, 3.2 GHz, 1 GB Ram (Core2 recommended)

**Screen:** 1024 x 768 pixel ( 1024 x 768 pixel recommended)

### A.1.3 Included

- Native Raytech USB Driver
- Documentation

### A.1.4 Options

- Database located on server
- Synchronize with external server

## A.2 Application Example

### A.2.1 Overview

The example depicted in Figure A.2 shows a powerful measuring system with remote control, data exchange and analysis. Pictured on the following

## APPENDIX A. RAYTECH T-BASE PRO



page (Figure A.2) is the Raytech Automatic Transformer Observing System called ATOS which is fully controlled by the T-Base Pro software. Add-Ons complete the functionality to fit into a transformer manufacturing test flow. It runs on a Windows based PC and is operated on an easy-to-use graphical user interface.

### **A.2.2 Description**

Raytech Automatic Transformer Observing System (ATOS) combined with T-Base Pro software is an extremely powerful system for transformer measurements. With one cabling, all winding resistance and turns ratio measurements are done easily. Operation of the devices can be done by touch screen, or on a remote computer using T-Base Pro. Compared to measurements with simple devices, measuring with an ATOS leads to drastically reduced measuring time and increased performance. Using T-Base Pro makes data collecting with a memory stick unnecessary.

## APPENDIX A. RAYTECH T-BASE PRO

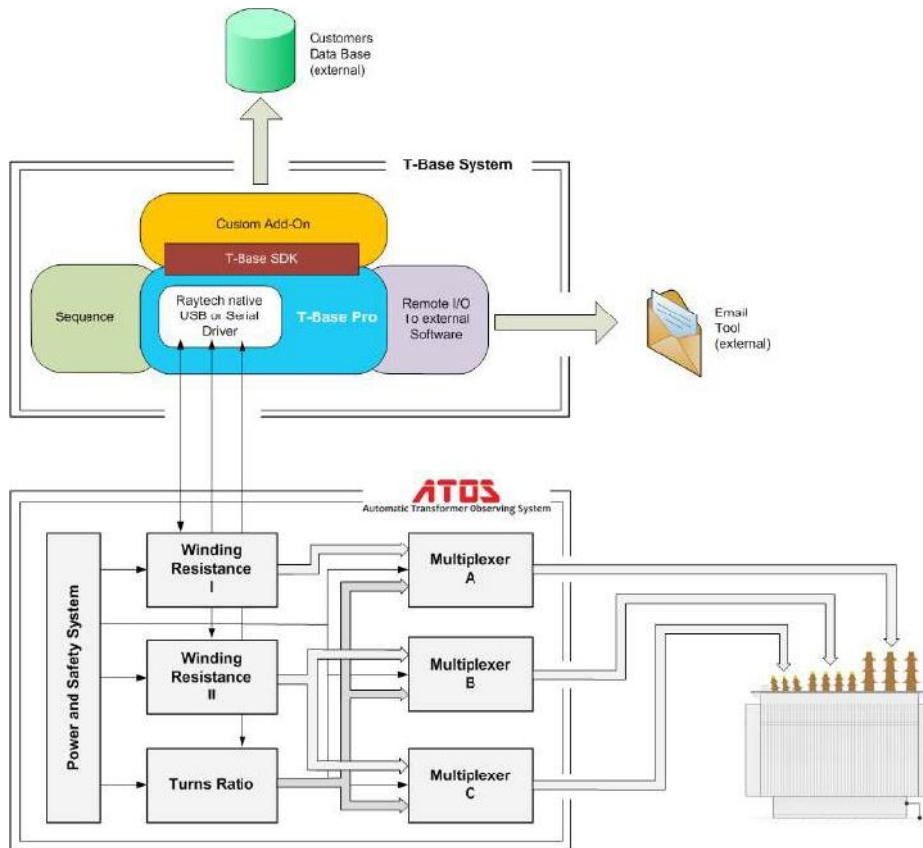

Figure A.2: T-Base Pro application example

ATOS components are connected by USB or RS232 to your computer. The software link from devices to the operating system is done by the *Raytech native Driver*. This software Driver is included with the T-Base Pro release.

With T-Base Pro, creating transformer profiles and importing and exporting of measurements are accomplished much easier than manually performing these operations.

Powerful search functions and a modern graphical user interface support users in handling transformer profiles and measurements. *Test Reports* are available in several output formats.

Complete automated transformer measurements are accomplished with the *Sequence Add-On*. All settings of Raytech devices are available by remote and can be configured individually, and any test procedure based on the available devices can be defined.



In the previous example (see Figure A.2), a Custom Add-On sends passed transformer measurements in the required format to the factory data base. Access to any data set in this data base is also provided by this Add-On. Add-Ons can be programmed by Raytech, a customer or a third party using the provided Software Development Kit (SDK). The SDK is described in Section A.4.2.

The Raytech Add-On *Remote I/O to External Software* sends email notifications to supervisors when a transformer is tested successfully or if a failure has occurred.

### A.3 Concept of T-Base Pro

The basic T-Base Pro software is free to everyone. It consists of the Raytech native driver, internal data base, possibilities to create and handle transformers and measurements and, of course, the graphical user interface.

A Software Development Kit (SDK) to create your own custom Add-On is also provided.

Proprietary Raytech Add-Ons are available as an option.

## A.4 Components of T-Base Pro

### A.4.1 T-Base Pro — totally free

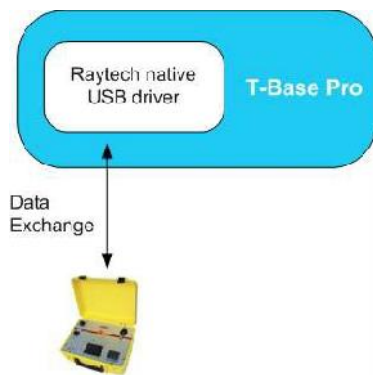

Figure A.3: T-Base Pro— totally free

- Import transformer name plate data and measuring results from devices via USB device, USB key or RS232 with a few clicks
- Generate transformer name plate data sets on your PC and export them to devices
- View measurement data in a table or diagram
- Generate, save and print test reports
- Use powerful search functions to find your measurements quickly
- Work with a clearly arranged user interface





### A.4.2 Create your Add-On with T-Base SDK

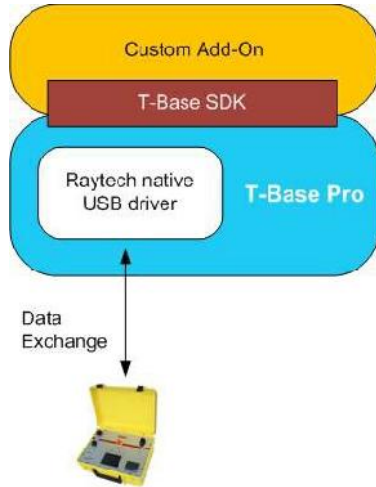

T-Base Pro is designed as an open platform. A Software Development Kit (SDK) to create custom Add-Ons easily is provided by Raytech.

Figure A.4: Create your Add-On with T-Base SDK

### A.4.3 T-Base Pro Remote Option for Raytech Devices

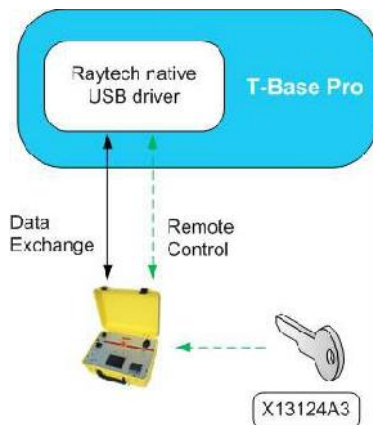

The T-Base Pro remote option of Raytech devices can be unlocked by entering a license key. An unlocked device can be remote controlled by a graphical user interface on T-Base Pro. No additional programming is needed. Every T-Base Pro can control several Raytech devices, as long as the license key has been entered and the devices are unlocked.

Figure A.5: T-Base Pro Remote Option for Raytech Devices



#### A.4.4 Proprietary Add-On—Sequence

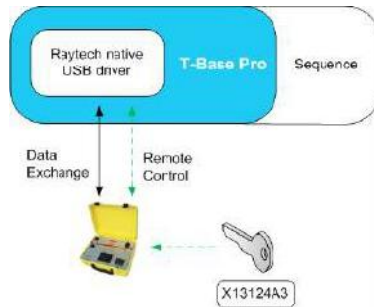

Figure A.6: Proprietary Add-On—Sequence

Sequence is an existing Add-On to control Raytech devices and doing complete transformer measurements in a free programmable measuring process, including winding resistance and turns ratio measurements. Test procedures can be defined individually. Remote Options needed for Raytech devices are included in Sequence.

#### A.4.5 Proprietary Add-On—Remote I/O to External Software

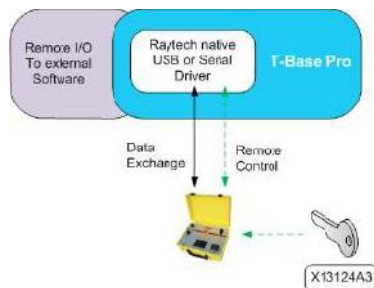

Figure A.7: Proprietary Add-On—Remote I/O to External Software

This is a basic Add-On provided by Raytech. It calls any program with a parameter on a PC. An XML file as return value is accepted.

### A.5 Graphical User Interface

Raytech T-Base Pro has a modern and comfortable graphical user interface depicted in Figures A.8 and A.9. Some of its components and basic functions are explained in the following pages.

Raytech T-Base Pro is a *full multi-tasking system*. For instance, a measurement with long duration can be started and while it is running, the user can create new profiles, exchange data with other devices, start another measurement and so on.

Every running process will create a new *ribbon tab* in the *ribbon menu* on top of the window.

# APPENDIX A. RAYTECH T-BASE PRO

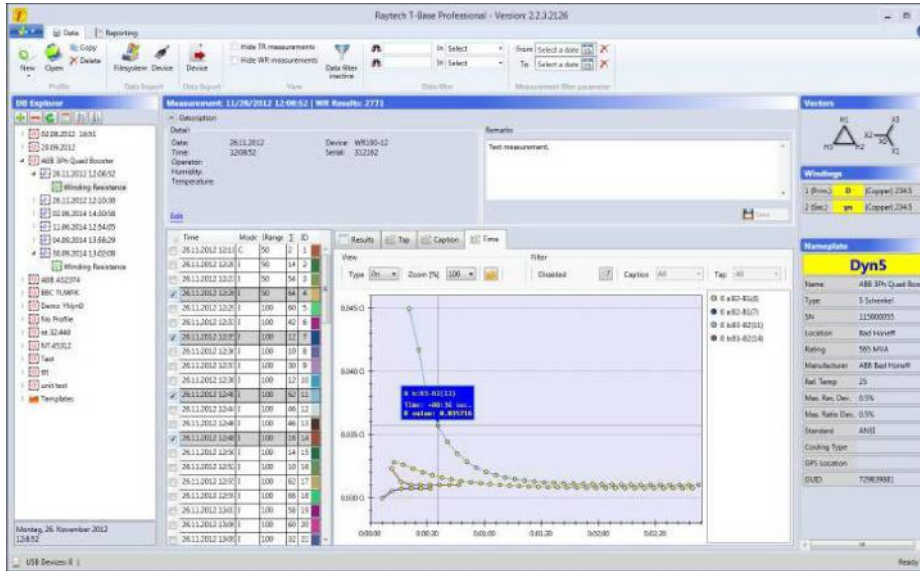

Figure A.8: T-Base Pro—Data management

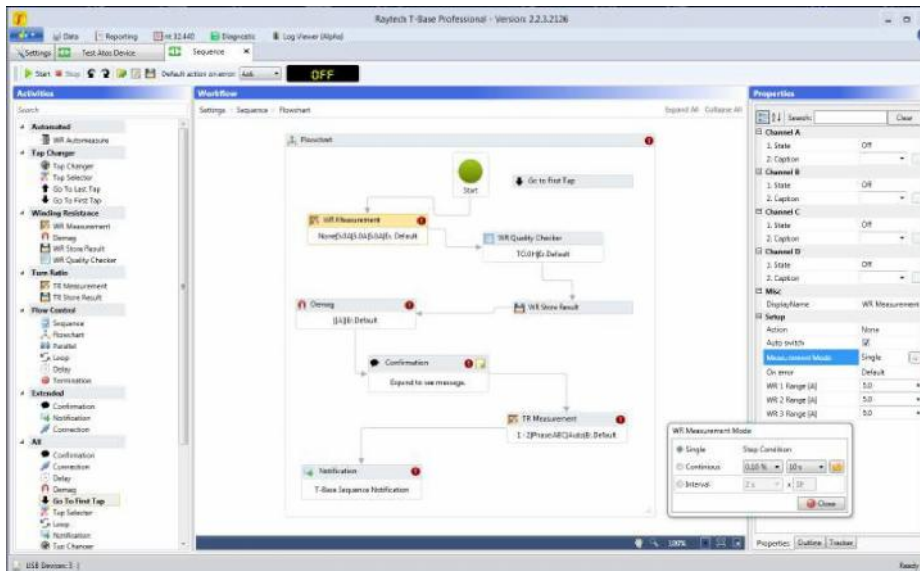

Figure A.9: T-Base Pro—Sequence



The *profile manager* on the left side of the window is an explorer style which shows all transformers, with measurements, stored in the data base. A hierarchic illustration helps to get a quick overview.

When a profile is selected on the left border in the *profile manager*, the most important information about a transformer and its profile are displayed. The *profile info* section is a useful tool to find a required profile when browsing manually through a transformer data base.

Details of selected profiles and measurements are shown in the *content window*. This section is built up dynamically and changes its content based on the selection in *profile manager*.

When remote control is chosen for a device a new *ribbon tab* is created and automatically selected. Running processes like remote control or data exchange will not be affected. The newly created *ribbon tab* may appear differently for several Raytech devices.

The *device control* section contains all options to set up a device and do measurements. With a few clicks a measurement is started and the results are displayed in the *results section* immediately.

## A.6 USB Driver for T-Base Pro

The USB Drivers must be activated to allow communication between the Raytech instrument and a computer. This is accomplished by entering a simple Service Code: 2001#



## ***Software Development (SDK)***

The SDK is a device management software with various possible applications. It is essentially a software layer (or driver) that resides between the Operating System (OS) IO system, custom Windows Application and Raytech instruments. The SDK with native Raytech USB Driver for Windows provides the OS with full device functionality, appearing to OS as a Raytech USB device. This software can also be used without native Raytech USB drivers to control the device over the standard RS-232 serial port.

It is a powerful tool to write easily customized Software to control the Raytech Instruments.

For more information download the SDK Quick Start Guide from the Raytech homepage [2].



## Command Syntax

It is possible to control the instrument over the RS-232 or the USB port with an external computer. It is also possible to write your own test program for a fully customized test procedure.

A description of all commands is stored on the delivered USB-Key. The newest version can always be downloaded from the Raytech homepage [2].

### C.1 Serial Interface

#### C.1.1 Command Syntax

The serial interface command syntax is formatted as follows (**LF** being line feed: ASCII 0x0A)

**Cmd**, [ Para [ , Para2 . . ] ] **LF**

- Separator for Parameters: ',' (comma: ASCII 0x2C)
- Numeric Format of Numbers: float (C - Language), '.' (full stop: ASCII 0x2E) as decimal point
- Format of Strings: all ASCII characters from 0x20 to 0xff
- Spaces are represented in the command syntax by a '\_' to increase readability.

#### C.1.2 Standard Response / Error Messages

Table C.1: CT-T1 RS-232 parameters

<b>Response</b>	<b>Description</b>
*1_Ok	Command successful
*2_Syntax_error	Command unknown
*3_Out_of_range	Parameter is out of allowed range
*4_Fail	Command is not allowed (at this time)
*5_Missing_parameter	Too few parameters
*6_Too_many_parameter	Too many parameters
*7_Out_of_Range_Meas	Range change not allowed while measuring
*8_Internal	Internal error occurred



## C.2 USB Interface

The USB-Slave interface (see Chapter 6.1.2) can be used to control the CT-T1.

The USB driver and an installation guide can be downloaded from the Raytech homepage [2].



**NOTE:**

The USB-driver installation is not necessary in order to use the RS-232 serial port for communication with the device.



## **USB Printer Info**

### **D.1 Printer Requirements**

The Printer must conform to Standard USB class 7.1 device. Nearly every Printer conforms as such with the exception of multifunction devices (e.g. All in One Printers).

Supported languages are:

- HP PCL
- Epson ESC/P 2
- Epson Stylus COLOR
- Canon BJ (300 dpi)
- Canon BJ (360 dpi)
- Epson LX (9-pin)

### **D.2 Suggested Printers**

Table D.1: Suggested Printers

<b>Ink-Jet</b>	<b>Laser</b>
Canon iP90	Brother HL-5240 (Tested)
Epson Stylus S20	Brother HL-2140
HP-Deskjet 6940	Brother HL-5240L
HP-Deskjet H470B	HP-Laserjet P1505N HP-
Deskjet H470WBT	HP-Laserjet P2055DN
Epson Stylus Office B40W	HP Color Laserjet CP2025N
	PocketJet 200
	PocketJet II

The information in this document is subject to change without notice.





## **Trouble Shooting**

When the CT-T1 instrument is powered on, an internal calibration and check sequence is performed. Upon completion of the check sequence the test set will proceed to the *Main Screen*. Should there be any problem detected with the test set an error message will appear.

### **E.1 System does not display anything:**

1. Check the display for any Initialization.
2. Check the fuse. The fuse is located on the top right of the front panel of the instrument (Element 1c of Figure 4.1 on page 21).

### **E.2 Touch Panel does not work:**

Connect a USB mouse to the USB port and control the instrument with it. The instrument will automatically display a cursor and everything can be done by mouse. Try to recalibrate the touch panel.

### **E.3 USB Memory Stick does not work:**

There are a few unsupported memory sticks available on the market. Please use another model or brand and try again.

### **E.4 Measurement cannot be turned on:**

Is the Emergency stop switch pushed in? Turn it counter clockwise to release.

### **E.5 No Data on Printout:**

Is the paper thermal paper? Is the paper inserted correctly?

CORRECT



INCORRECT



\*\*Pictures for reference only and may differ than actual product.



## **Glossary**

ANSI/IEEE C57.13.1.....	15
IEEE Guide for Field Testing of Relaying Current Transformers	
ASA American Standards Association (now ANSI).....	18
ASA 10/50 .....	17
The point in the square log-log graph where increasing the voltage by 10 % leads to an increase of the current by 50 %.	
ATOS Automatic Transformer Observing System .....	40
CT Current Transformer.....	15
DEG Degauss .....	15
EXC Excitation / Knee point .....	16
IEC 60044-1.....	15
Instrument transformers - Part 1: Current transformers	
IEEE Institute of Electrical and Electronics Engineers.....	18
IEEE 30° .....	17
The knee point of a CT with a gapped core as defined by the Institute of Electrical and Electronics Engineers (IEEE) the tangents slope is 30° in the log-log-graph with square decades.	
IEEE 45° .....	17
The knee point of a CT with a non-gapped core as defined by the Institute of Electrical and Electronics Engineers (IEEE) the tangents slope is 45° in the log-log-graph with square decades (see Definition 3.11(A) of [5])	
Remanence.....	16
Residual induction stored in the core of the CT under test caused by partial magnetization induced by a DC current or an incomplete shutdown cycle	
Square log-log Graph .....	13
The graph used to display the results shows two log-axis with each decade area forming a square.	
T-Base Pro .....	39
Powerful tool to remotely control Raytech test instruments, exchange data and analyze measured data	
TR Turns ratio.....	16



## ***Bibliography***

- [1] Raytech T-Base. <http://http://tbase.raytech.ch>.
- [2] Raytech USA. <http://www.raytechusa.com>.
- [3] Specification for Current Transformers. *BS 3938*, 1973.
- [4] The Authoritative Dictionary of IEEE Standards Terms, Seventh Edition. *IEEE Std 100-2000*, pages 1–1362, Dec 2000.
- [5] IEEE Guide for the Application of Current Transformers Used for Protective Relaying Purposes. *IEEE Std C37.110-2007 (Revision of Std C37.110- 1996)*, pages 1–90, April 2008.
- [6] IEEE. IEEE Guide for Field Testing of Relaying Current Transformers. *IEEE Std C57.13.1-2006*, pages 1–38, Feb 2007.



## ***Index***

ATOS, 40

Degauss, 15

Excitation, 16

Firmware update, 34

Knee point, 16

- ASA 10/50, 18
- IEEE 30°, 18
- IEEE 45°, 18

Measurement

- Degauss, 15
- Excitation, 16
- Knee point, 16
- Square log-log Graph, 13
- Turns ratio, 16

Square log-log Graph, 13

Standards

- ANSI/IEEE C57.12.90, 15
- ANSI/IEEE C57.13.1, 15
- IEC 60044-1, 15

T-Base Pro, 39

Turns ratio, 16



## **Warranty Conditions**

Raytech USA, Inc. warrants to the original purchaser that its products shall be free from defects in material and workmanship under normal use and service for a period of 60 months from the original date of shipment. An additional extended warranty period is provided, at cost to the end user, for the products covered under this warranty if the products are returned on each calendar year from the original date of shipment, prepaid, to Raytech USA, for system evaluation.

The obligation of Raytech USA, Inc. under this warranty is limited, in its exclusive option, to repair, replace, or issue credit for parts or materials which prove to be defective, and is subject to purchaser's compliance with the Raytech USA, Inc. warranty claim procedure as set forth within this manual. Raytech USA, Inc. shall at their option and expense, repair or replace any part or parts that prove to be defective within the warranty limitation period irrespective of the operating time of the test equipment, provided that the cause of the defect occurred prior to the time at which the risk was passed. The purchaser is obligated to immediately notify Raytech USA, Inc. in writing of any defects of the supplied test equipment. Raytech USA, Inc. must always be given the opportunity to rectify a defect within a reasonable amount of time. The purchaser shall grant adequate amount of time that the test equipment shall be repaired.

This warranty covers only those parts and/or materials deemed to be defective resulting from manufacturer's workmanship. The liability of Raytech USA, Inc. shall be limited to the repair, replacement, or issuance of credit for parts deemed defective within the meaning of this warranty. Costs for all transportation, labor or other expenses that may have occurred incidental to the inspection, repair, replacement, or issuance of credit for such parts and/or materials shall be the sole responsibility of purchaser. This warranty shall not apply to any accessories, parts, or materials not manufactured or supplied by Raytech USA, Inc.

Equipment must be returned prepaid with a Return Material Authorization (RMA) to:

Raytech USA, Inc.  
118 S. 2nd Street  
Perkasie, PA 18944 USA  
Tel. + 267 404 2676 Fax. + 267 404 2685  
[www.RaytechUSA.com](http://www.RaytechUSA.com)



## WARRANTY CONDITIONS

### Limitation of Warranty

The foregoing warranty shall not apply to any or all of the following circumstances:

- Defects resulting from improper and unauthorized modifications or misuse and abuse of the product, negligence, alteration, modification, faulty installation by the customer, customer's agents or employees,
- Attempted or actual dismantling, disassembling, service or repair by any person, firm, or corporation not specifically authorized in writing by Raytech USA,
- Defects caused by or due to handling by carrier, or incurred during shipment, trans-shipment, or other move, and/or
- Inadequate maintenance by the customer, second source supplied software or interfacing, operation outside the environmental limits, or improper site preparation.

Exclusive remedies provided herein are the customer's sole and exclusive remedies. Raytech USA, Inc. shall not be liable for any damages resulting from the use of this equipment whether direct, indirect, special, incidental, or consequential damages, or whether based on contract, tort, or any other legal theory.



**NOTE:**

No other warranty is expressed or implied.

### Arbitration

All disputes arising out of or in connection with the warranty agreement between the purchaser and Raytech USA, Inc. and including those regarding the legal validity of the warranty and this arbitration clause shall be settled out of court and may be referred to arbitration for final decision.

Any disputes between the purchaser and Raytech USA, Inc. shall be settled according to the rules of settlement and arbitration of the chamber of commerce in Pennsylvania by one or more arbitrators appointed also according to the rules of arbitration of the chamber of commerce in Pennsylvania.